



Hawthorn**Timber**



Magply

MOS BOARD

Timber Frame

Render Systems

Steel Frame Systems

Rainscreen Cladding

Modular Build

Spandrel Panels

SIP Panels

Pattressing

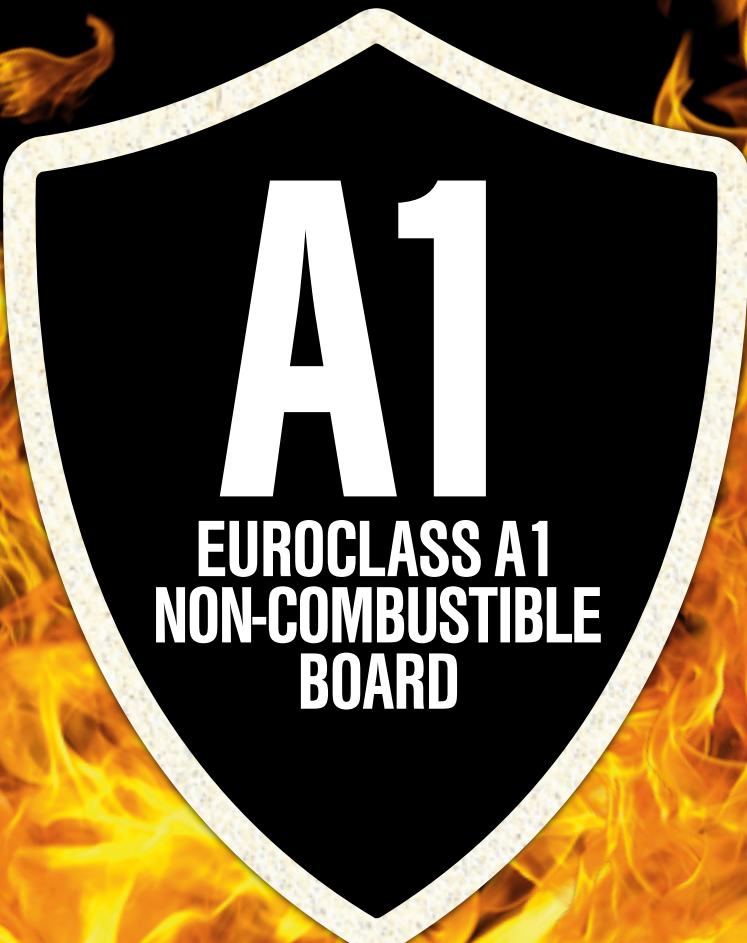

EUROCLASS A1
PERFORMANCE



ETA 17/0976



MOISTURE
PROTECTION



STRONG AND
EASY TO USE



ENVIRONMENTALLY
FRIENDLY



BREATHABLE



MOULD
RESISTANT



SOUND
REDUCTION



CLASS 0

TIMBER FRAME (Rockwool)

STANDARD: BS 476: PART 22: 1987 | TEST DATE: 19th JUNE 2015

91
MINUTES

INTEGRITY

86
MINUTES

INSULATION

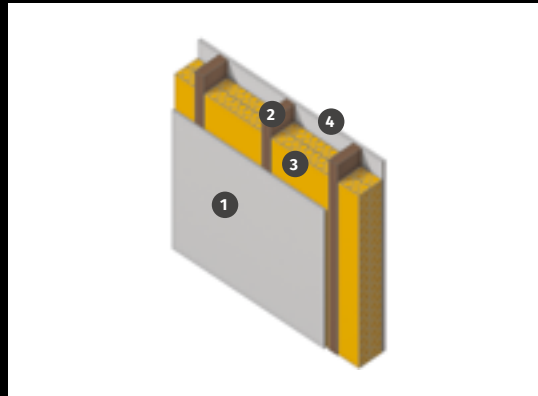

- 1 9mm Magply
- 2 38mm x 140mm Section
- 3 2 x Layers Rockwool
- 4 15mm Gyroc Fireline

TIMBER FRAME (PIR)

STANDARD: BS EN 1364 - 1 2015 | TEST DATE: 19th JULY 2016

75
MINUTES

INTEGRITY

66
MINUTES

INSULATION

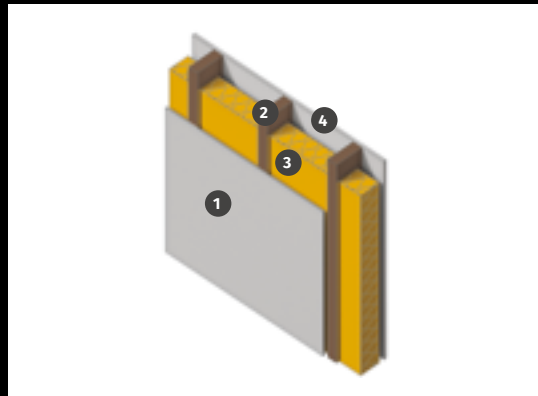

- 1 9mm Magply
- 2 38mm x 140mm Section
- 3 110mm Polyisocyanurate
- 4 15mm Knauf Fire Panel

SPANDREL PANEL (UN-INSULATED)

STANDARD: BS 476: PART 22: 1987 | TEST DATE: 17th FEBRUARY 2018

132
MINUTES

INTEGRITY

61
MINUTES

INSULATION

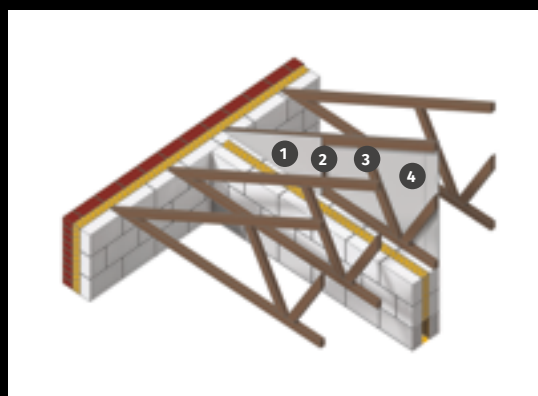

- 1 12mm Magply
- 2 100mm Cover Strip
- 3 38mm x 89mm Section
- 4 12mm Magply



LOAD BEARING WALL

STANDARD: BS EN 1365-1: 2012 | TEST DATE: 13th OCTOBER 2016



INTEGRITY



INSULATION

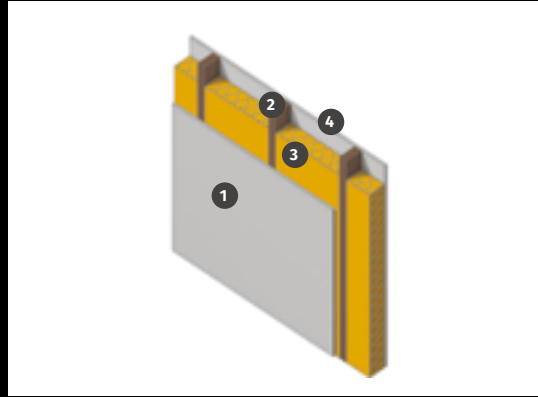

- 1 9mm Magply
- 2 38mm x 90mm Section
- 3 Knauf Insulation
- 4 9mm Magply

STEEL FRAME PARTITION

STANDARD: BS EN 1364 - 1 2015 | TEST DATE: 31st MARCH 2017



INTEGRITY



INSULATION

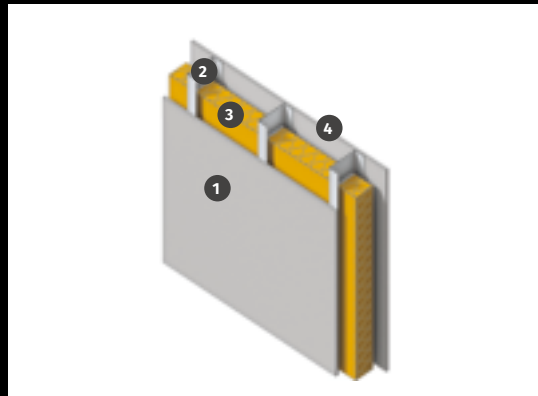

- 1 9mm Magply
- 2 70mm x 32mm Section
- 3 70mm Mineral Wool
- 4 9mm Magply

SPANDREL PANEL

STANDARD: BS476 Part 22:1987 Clause 5 | TEST DATE: 17th AUGUST 2017



INTEGRITY



INSULATION

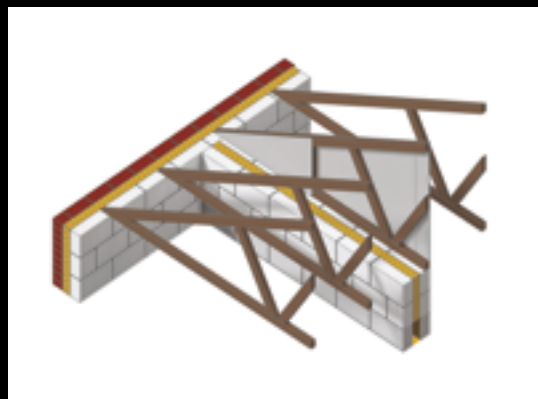

- ▶ 12mm Magply
- ▶ 38mm x 89mm Section
- ▶ 50mm Cavity
- ▶ 38mm x 89mm Section
- ▶ 12mm Magply



LOAD BEARING WALL

STANDARD: BS EN 1365-1: 2012 | TEST DATE: 13th JULY 2018



INTEGRITY



INSULATION

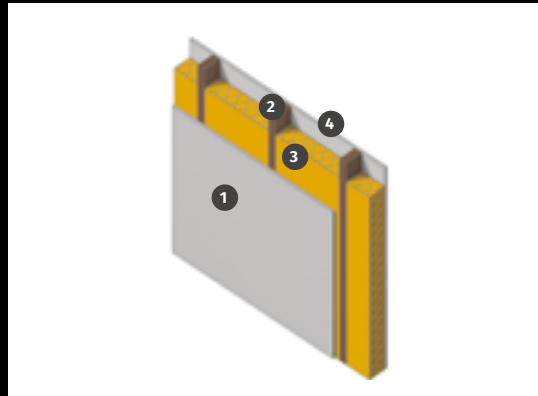

- 1 12mm Magply
- 2 38mm x 89mm Timber Frame
- 3 90mm Knauf Earthwool
- 4 9mm OSB

LOAD BEARING WALL (Light Gauge steel frame)

STANDARD: BS EN 1365 - 1: 2012 | TEST DATE: 26th FEBRUARY 2019



INTEGRITY



INSULATION

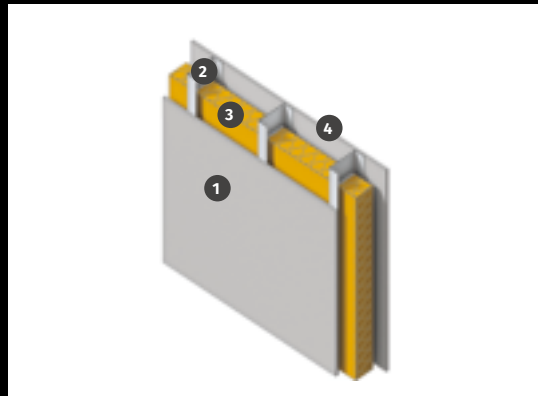

- 1 12mm Magply with 70mm Internal Cover Strip
- 2 100mm LGS Frame
- 3 100mm Rockwool
- 4 12mm Magply

EXTERNAL CLADDING

STANDARD: EN 13501-1:2007 A1: 2009 | TEST DATE: 14th JUNE 2016



A1 CLASSIFICATION
OF REACTION TO FIRE
PERFORMANCE

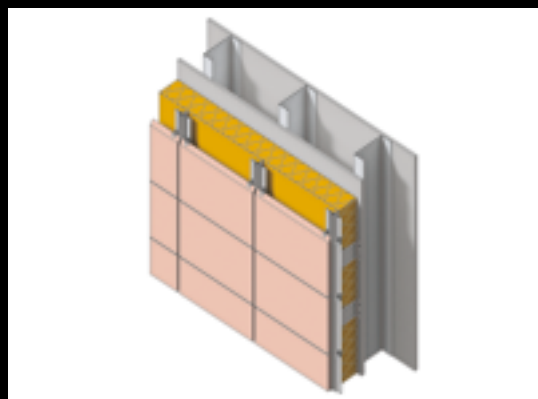

In line with the Building Control Alliance Technical note 18; 'use of Combustible Cladding Materials on residential buildings paragraph 12.7 of AD B2' - use materials of limited combustibility throughout the cladding system.



Introduction

The Magply Euroclass A1 board can be used as a fire mitigation sheathing board for Timber Frame, Steel Frame, Rainscreen Cladding, SIP Panels, Spandrel Panels and Modular Build.

Magply features a magnesium oxysulfate formulation which is manufactured from a production process that ensures a very low chloride content enhancing both stability and durability. Magply carries internationally recognised accreditations confirming the boards' ability to deliver fire integrity, racking strength, impact and pull-out resistance.

Thicknesses (mm): 3,6,9,12,18,20
(2400mm ,2440mm, 3050mm x 1200mm sheets)

Thickness (mm)	Width (mm)	Length (mm)	Weight per board (Kg)	Surface m ²
9	1200	2400	28	2.88
		2700	32	3.24
12	1200	2400	38	2.88



Thermal Conductivity	0.19 W/mK
Fire Classification	Class 0 Euroclass EN13501* A1 (Non-Combustible)
Reaction to Fire	Passed BS EN 1716 Reaction to Fire* Passed
Appearance	Solid flat sheet board
Colour & Odour	White, Odourless Change of State None
Vapour Resistance	Vapour Resistance 0.31 MNs/g (EN ISO 12572*)
Melting point	Melting point: 2400°C
Vapour pressure	EN ISO 12572: 2016 = 0.31 MNs.g-1.
Solubility	Solubility: Insoluble in Water
Acoustic	9mm Rw 28dB 12mm Rw 29dB 20mm Rw 31dB EN ISO 717-1:2013

For more information please contact: 01482 228159



Magply

MOS BOARD



TESTED & CERTIFIED BY



LUCIDEON
insight creating advantage



ASSOCIATIONS



LIGHT STEEL FRAME
ASSOCIATION
SUPPLY CHAIN MEMBER

FOR MORE INFORMATION



Hawthorn Timber

www.hawthorntimber.co.uk

enquiries@hawthorntimber.co.uk

01482 228159